

# Rochester Sensors Gauges and Senders



The Rochester Sensors range of engines monitoring instrumentation comprises reliable and cost-effective gauges for use with 10 – 180Ω resistance match senders.

Incorporating integral back lighting, Rochester Sensors gauges monitor oil temperature and pressure, water temperature, battery volts and fuel level.

## SPECIFICATIONS

### Dimensions

See diagram

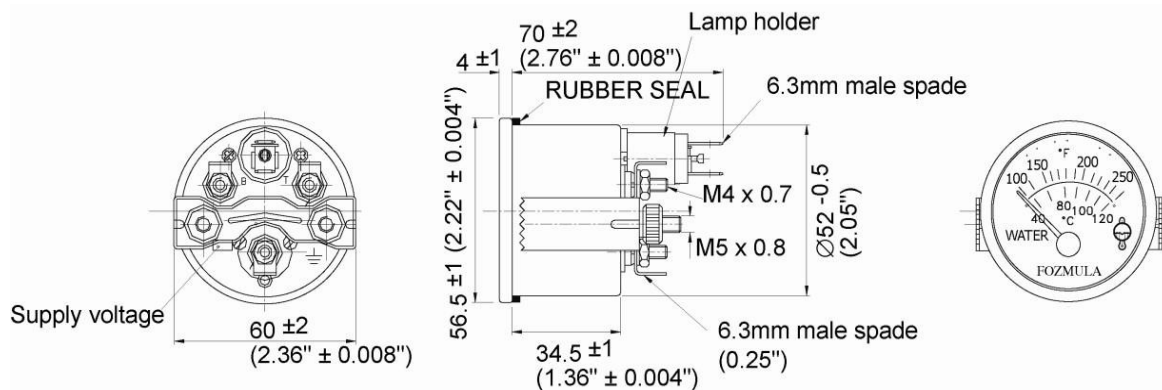

### Electrical

**Supply Voltage:** 12VDC (8/16 VDC) or 24VDC (16-32VDC)  
**Resistance match:** Linear 10 – 180Ω  
**Connections:** M4 x 0.7 studs and 6.3mm spades

### Construction

**Casing:** Steel zinc plated and passivated **Window:** Glass  
**Bezel:** Matt black

### Accuracy

**Tolerance:** Oil pressure, oil and water temp ±5% of the full-scale value @25°C (77°F)

Part Number	Voltage	Description	Part Number	Voltage	Description
V120921	12V	Oil pressure, 0 – 10 Bar (0-150 psi)	V210947	12/24V	50 – 0 – 50A
V120922	24V	Oil pressure, 0 – 10 Bar (0-150 psi)	V210948	12/24V	60 – 0 – 60A
V120923	12V	Oil pressure, 0 – 5 Bar (0-80 psi)	V220936	12V	Voltmeter
V120924	24V	Oil pressure, 0 – 5 Bar (0-80 psi)	V220937	24V	Voltmeter
V270961	12V	Water temp, 40 – 120°C (100°F to 250°F)	V260931	12V	Fuel level
V270962	24V	Water temp, 40 – 120°C (100°F to 250°F)	V260932	24V	Fuel level
V270963	12V	Oil temp, 50 – 150°C (120°F to 300°F)			
V270964	24V	Oil temp, 50 – 150°C (120°F to 300°F)			