

T/LL350 Liquid Level Sensor



The **T/LL350** series is a range of highly advanced sensors for continuously measuring the contents of a tank. The unique feature of the T/LL350 is that it auto compensates when a liquid with a different dielectric constant is used. For example, if it is used in a tank of conventional diesel, then the user can refill with bio-diesel and the sensor will correct the output level automatically.

Options include a high/low level alarm point, fitment of any suitable connector and compensation for non-linear shaped tanks.



SPECIFICATION

Liquid Types

Diesel, biodiesel, kerosene, petrol, water or any liquid which is compatible with the materials of construction.

Construction

Housing: Die cast aluminium & stainless steel
Sensor tube: Anodised aluminium
Wetted Materials: PTFE, polypropylene, Viton, aluminium & stainless steel

Dimensions

Probe length: Min 150 mm
 Max 2000 mm static applications & 1000 mm on mobile applications

Electrical

Supply voltage: 9-32 VDC with 80 V over voltage protection
Supply current: 15 mA@12 VDC + output load
Connections: 430 mm long 18 AWG XLPE flying leads#

Outputs

Resistive: Any values between 3-500 Ω or 500-3 Ω (3 Ω Steps)
Resolution: 3 Ω
Max dissipation: 250 mW
Current: 0-20 mA, 4-20 mA
Resolution: 20 μA
Max load: 250 Ω (Including interconnecting cable resistance)
Voltage:
 12 VDC system: Any values between 0-5 V/5-0 V
 24 VDC system: Any values between 0-10 V/10-0 V
Resolution: 10 mV
Max Load: 10 mA source (dependent on minimum supply voltage)
Accuracy: ±2.0% of probe length @ 20 °C (+68 °F) in diesel (For probes lengths 300 mm and above)

Environmental Ratings

Operating Temperature: -20 °C to +85 °C (-4 °F to +185 °F)
Sealing: IP67
Weight: 300 g (10 oz) (1000 mm long unit)
Max tank pressure: 0.75 bar (10 psi)
EMC: Type approval in accordance with EN ISO 13766:2006
Vibration: 500 mm sensor type tested to 1.88 grms to BS EN 60068-2-64:1993*
Shock: 500 ms⁻², 11 ms to BS EN 60068-2-27:1993

Options

Alarm: One position at either high level (switch to ground above level) or low level (switch to ground below level). Switch point can be set between 7% and 90% of measuring range (hysteresis 5%).
Max load: 100 mA.
Custom empty/full points: Specific empty and full levels can be provided within the allowable measurement range of the probe.
Non-linear Tanks: Compensation for non-linear tank shapes available.
Connections: Any suitable customer specified connector can be fitted. Terminated wire ends should be fitted with suitably sealed connectors to maintain specified IP rating.
F: Due to 3 Ω resolution, accuracy of resistive output variants is specified accuracy ±3 Ω.

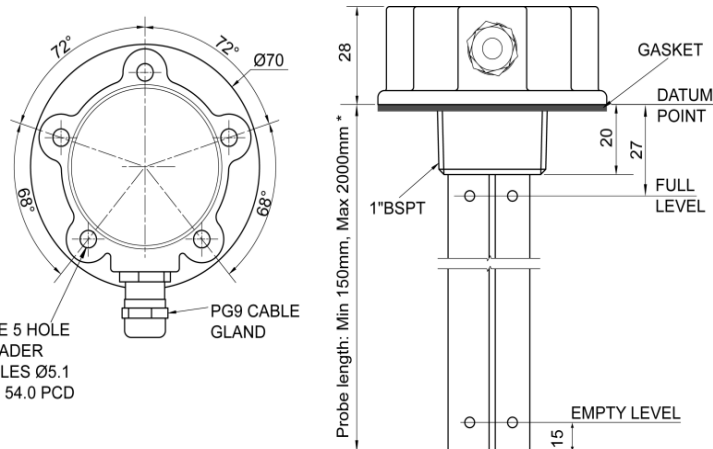

* Up to 1000mm in mobile applications or up to 2000mm in static applications.

Model Variant Table	
Model No	Output
T/LL350	Resistive
T/LL351	Voltage
T/LL352	Current
T/LL353	Resistive + alarm
T/LL354	Voltage + alarm
T/LL355	Current + alarm

* Vibration Testing	
Frequency	
10	0.005
150	0.020
220	0.010
350	0.002