

T/LL122 Adjustable Float Switch

Assembly Instructions

General Information

1. The T/LL122 is an electrical device which can be operated up to 240 volts. The float switch should be properly earthed, and the wiring checked by a competent person before use.
2. The T/LL122 is designed to be installed from outside through the top of the tank.
3. The T/LL122 comes with a standard 1" BSP threaded header and sealing washer.
4. Care should be taken when installing the T/LL122 that the stem is not damaged. The float clip should not be moved, or the float alignment with the electrical switch may be lost.
5. The T/LL122 has a factory-set switching configuration normally closed, i.e. open on rise. The switching operation can be altered to normally closed, i.e. close on rise configuration, by removing the split pin at the end of the system and reversing the float.
6. When the controlled circuit is inductive, suppression should be used to protect the switch contacts (a number of suppression circuits are shown overleaf). A varistor is supplied, which would provide sufficient protection to your float switch in most operations. This should be connected as in suppression circuit 2. However, Rochester Sensors recommend the use of appropriate suppression components for the specific circuit configuration (as per the appropriate suppression circuit diagram).
7. Please contact our engineering department if you require any further assistance.

Assembly of T/LL122

1. Cut the stem to the required length using tube wheel cutters
2. Slide the tube nut and olive onto the float switch stem
3. Thread the wires through the header
4. Insert the stem into the header until it butts up against the shoulder
5. Tighten the tube nut into the header until the olive is squeezed onto the stem.
6. Shorten wires to 18mm above header and strip back 5mm of insulation from each wire (do not pull-on wires while stripping insulation as this may damage the reed switch).
7. Thread the wires through the central hole of the connector gasket.
8. Solder the wires to the connector base according to your wiring convention. If you have no wiring convention, you may use the following guide to wire up the unit:
 - a. Connect one brown wire to terminal 1 (reed switch).
 - b. Connect one red wire to terminal 2 (if temperature switch variant supplied).
 - c. Connect one brown and one red wire to terminal 3 (common).
9. Align the rubber gasket and connector base with the screw holes in the header (securing and earth terminal holes). Screw in place using the 2 longer securing screws provided.
10. Screw the shorter earth screw through the earth terminal into the corresponding hole in the header.
11. Wire up the connector top, keeping to the wiring convention used in 8 (above).
12. Test the unit according to the "Electrical testing" overleaf.
13. Align the connector tags of the connector top to those of the base, and then secure to the base with the securing screw provided in the top.

NOTE: Rochester Sensors recommend that the wiring of the T/LL122 unit is carried out by a competent trained electrician.

Electrical testing:

Test Between

1. Connector earth tag to stem
2. Conductor pins to earth tag, tested individually in turn.
- 3a. Conductor pins 1 and 3.
- 3b. Conductor pins 2 and 3 (for thermal switch variants only).

Required indication

Continuity
No.
Continuity broken when float rises (unless float has been reversed as in 5. Of General Information).
Check expected switch condition.

1. Low switching currents

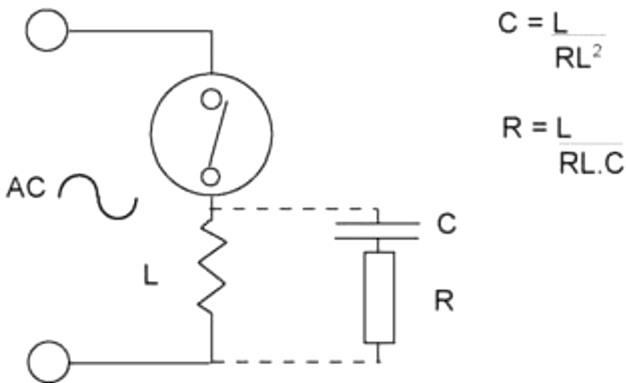

2. Higher switching currents

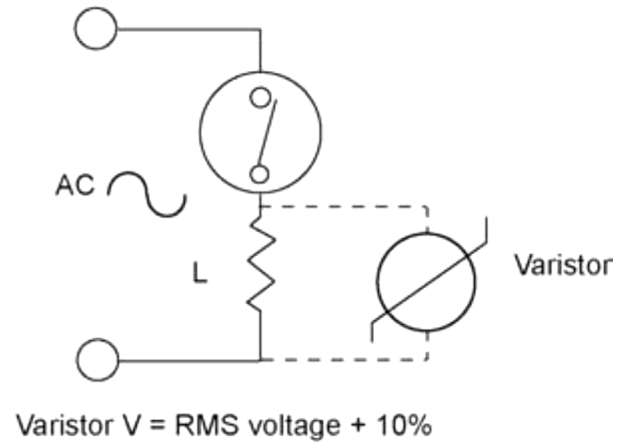

3. DC switching currents

